

# P.C.B. MOUNTING HOLE SPECIFICATIONS

P.C.B. MOUNTING HOLE SPECIFICATIONS

**TYPE A**

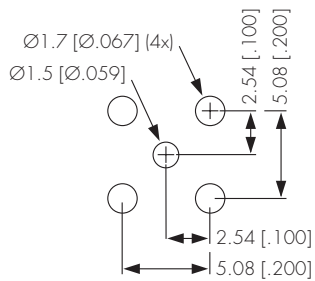

**TYPE B**

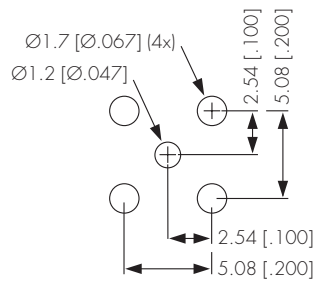

**TYPE C**

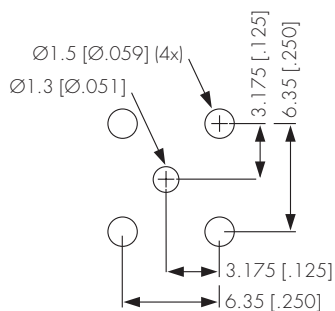

**TYPE F**

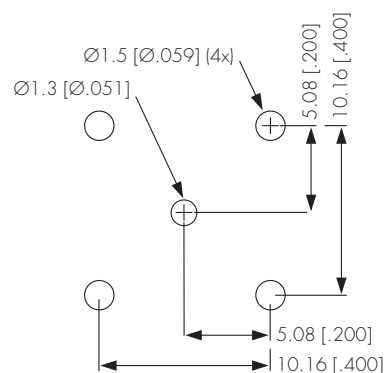

**TYPE G**

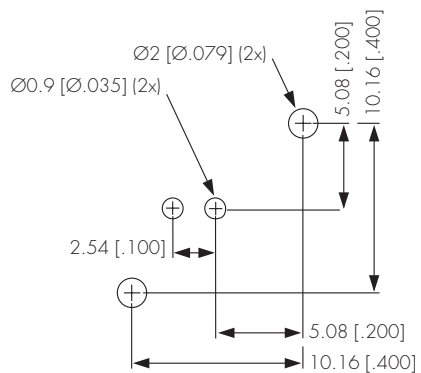

**TYPE H**

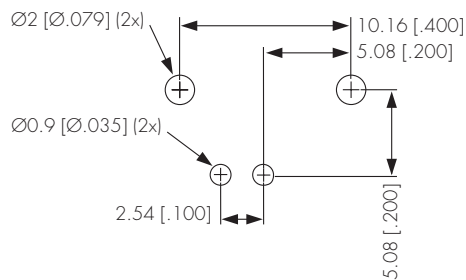

**TYPE L**

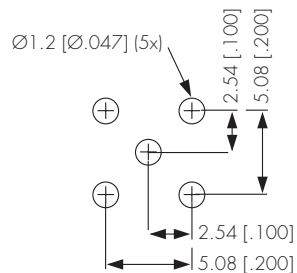

**TYPE M**

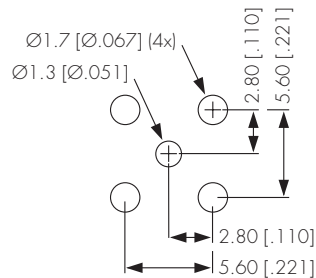

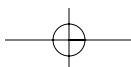
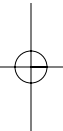
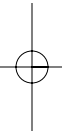
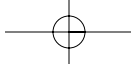

## CABLE ASSEMBLY INSTRUCTIONS

### SOLDER (SEMI-RIGID)

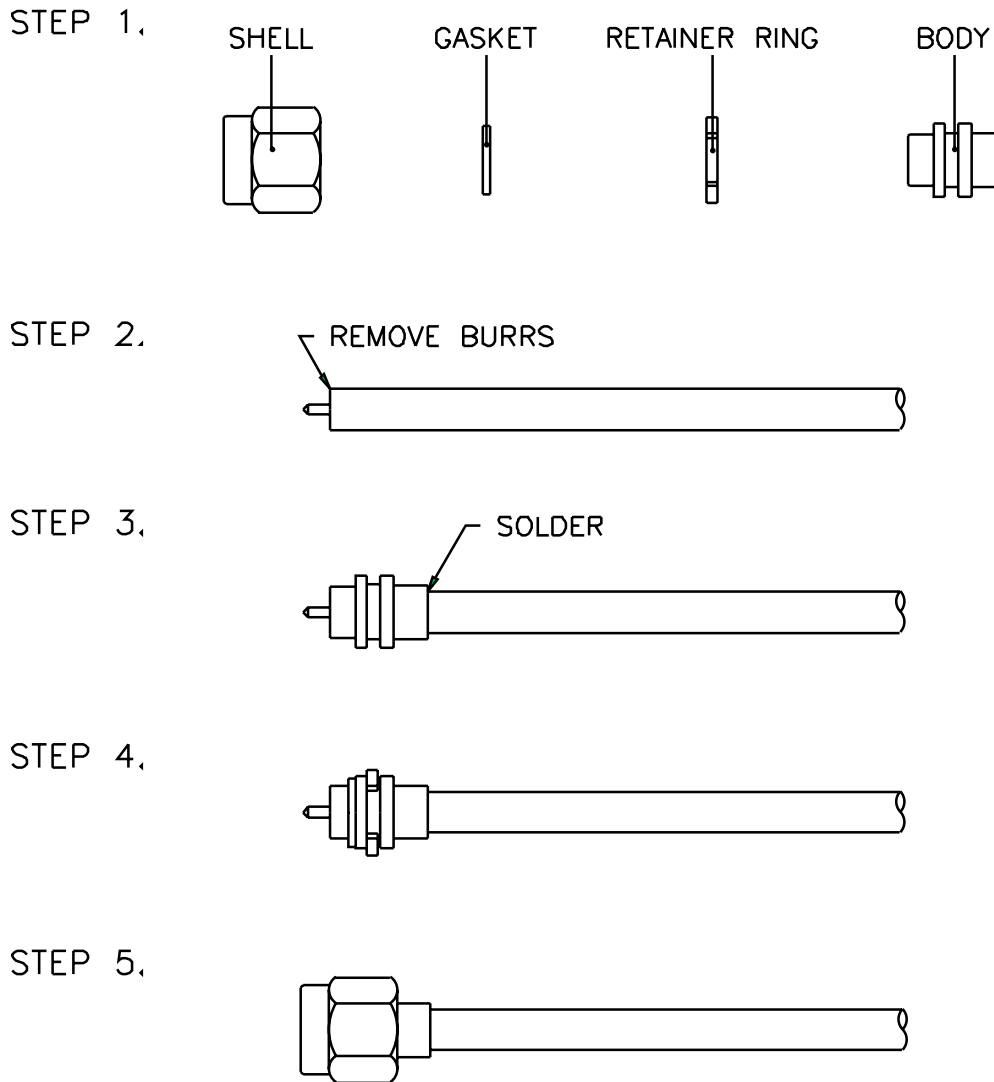

- STEP 1. All parts of the connector are shown.
- STEP 2. Strip the inner conductor, dielectric, and jacket as per "RECOMMENDED CABLE STRIPPING DIM'S" in catalog.
- STEP 3. Solder the BODY to cable as shown. (Avoid excessive heat which may distort dielectric).
- STEP 4. Place the RETAINER RING in the groove of BODY, and put the GASKET in the position as shown.
- STEP 5. Compress the BODY assembly and assemble the SHELL as shown.

## CABLE ASSEMBLY INSTRUCTIONS

### SOLDER (SEMI-RIGID)

STEP 1.

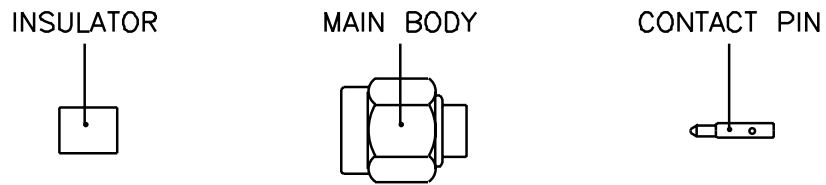

STEP 2.

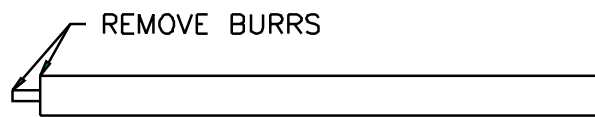

STEP 3.



STEP 4.

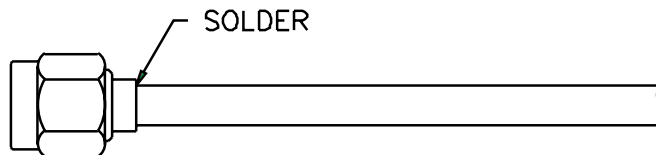

- STEP 1. All parts of the connector are shown.
- STEP 2. Strip the inner conductor, dielectric, and jacket as per "RECOMMENDED CABLE STRIPPING DIM'S" in catalog.
- STEP 3. Insert inner conductor into the CONTACT PIN and solder it as shown.
- STEP 4. Solder the MAIN BODY to cable as shown (Avoid excessive heat which may distort dielectric). Then press the INSULATOR into the MAIN BODY until it stops.

## CABLE ASSEMBLY INSTRUCTIONS

### SOLDER (.047 SEMI-RIGID)

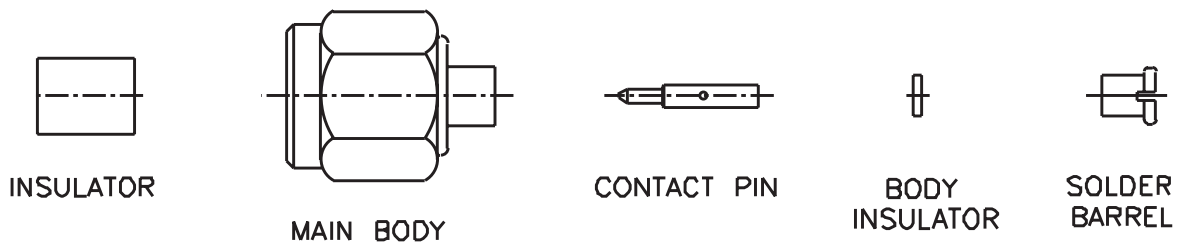

- STEP 1. All parts of the connector are shown.
- STEP 2. Strip cable as per "RECOMMENDED CABLE STRIPPING DIM'S" in catalog.
- STEP 3. Insert SOLDER BARREL, BODY INSULATOR and center CONTACT PIN onto cable.
- STEP 4. Assemble cable into connector body and solder barrel onto main connector body. (Avoid excessive heat which may distort dielectric).
- STEP 5. Press the INSULATOR into the MAIN BODY until it stops.

## CABLE ASSEMBLY INSTRUCTIONS

### SOLDER (SEMI-RIGID)

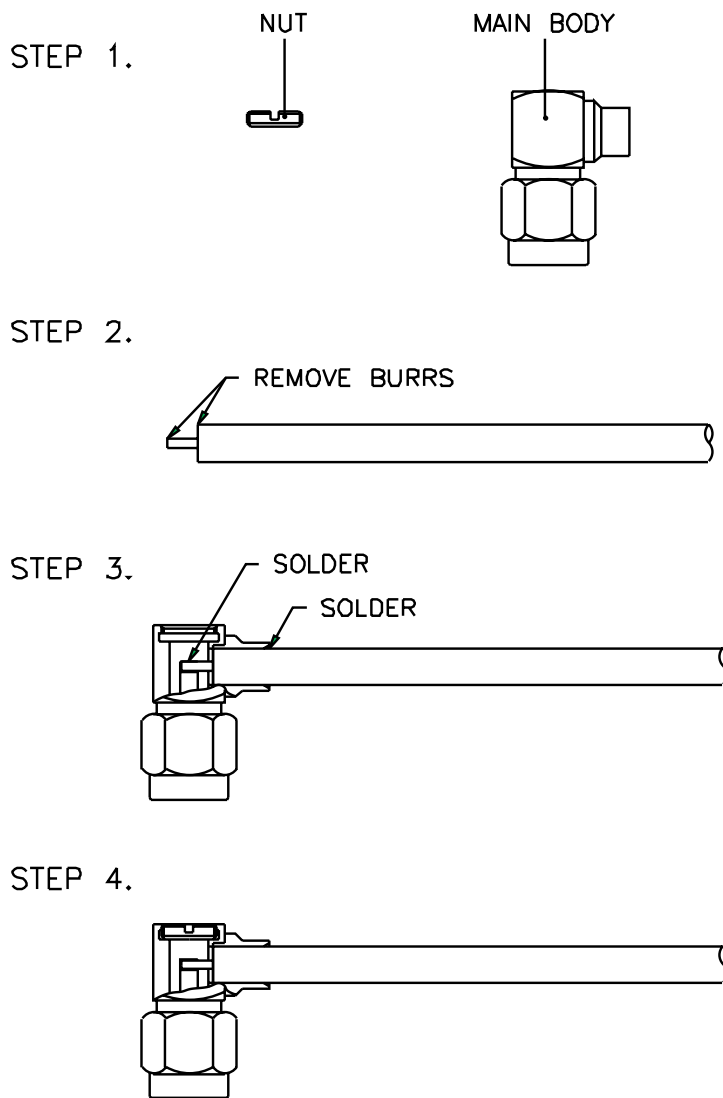

- STEP 1. All parts of the connector are shown.
- STEP 2. Strip the inner conductor, dielectric, and jacket as per "RECOMMENDED CABLE STRIPPING DIM'S" in catalog.
- STEP 3. Solder inner conductor to the contact pin of MAIN BODY, and solder cable jacket to the MAIN BODY as shown.
- STEP 4. Screw the NUT into the MAIN BODY until it stops.

# CABLE ASSEMBLY INSTRUCTIONS

## SOLDER (SEMI-RIGID)

STEP 1.

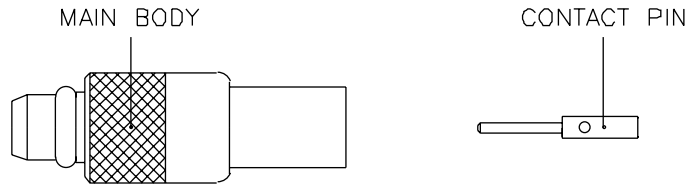

STEP 2.

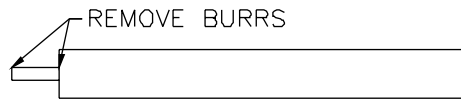

STEP 3.

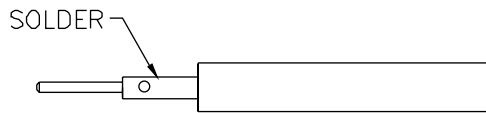

STEP 4.

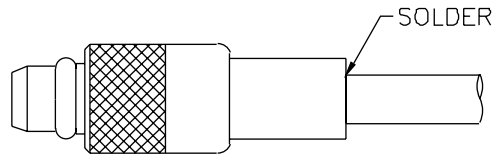

- STEP 1. All parts of the connector are shown.
- STEP 2. Strip the inner conductor, dielectric, and jacket as per "RECOMMENDED CABLE STRIPPING DIM'S" in catalog.
- STEP 3. Insert inner conductor into the CONTACT PIN and solder it as shown.
- STEP 4. Solder the MAIN BODY to cable as shown.



## CABLE ASSEMBLY INSTRUCTIONS

### SOLDER (SEMI-RIGID)

#### STEP 1.

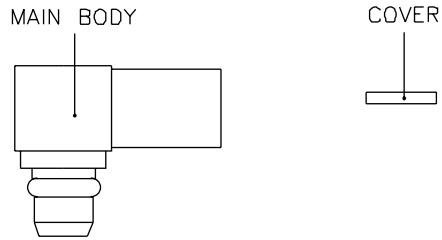

#### STEP 2.

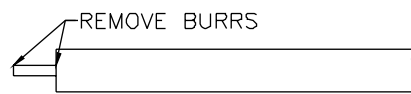

#### STEP 3.

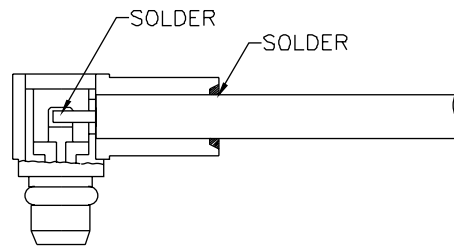

#### STEP 4.

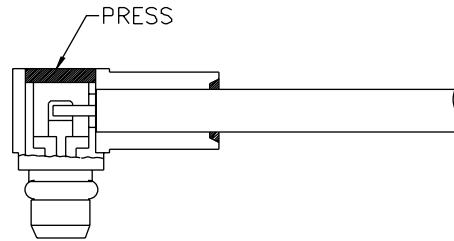

- STEP 1. All parts of the connector are shown.
- STEP 2. Strip the inner conductor, dielectric, and jacket as per "RECOMMENDED CABLE STRIPPING DIM'S" in catalog.
- STEP 3. Solder inner conductor to the contact pin of MAIN BODY, and solder cable jacket to the MAIN BODY as shown.
- STEP 4. Press the COVER into the MAIN BODY until it is flat with the MAIN BODY.

## CABLE ASSEMBLY INSTRUCTIONS

### SOLDER (SEMI-RIGID)

#### STEP 1.

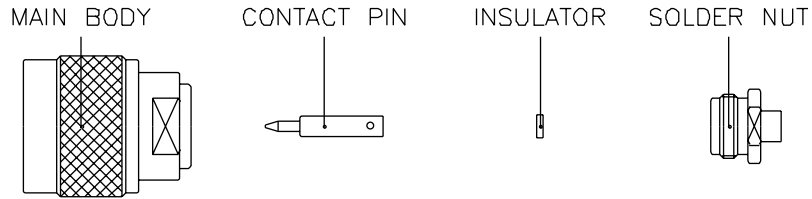

#### STEP 2.

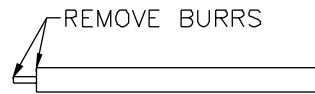

#### STEP 3.



#### STEP 4.

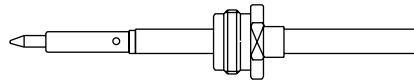

#### STEP 5.

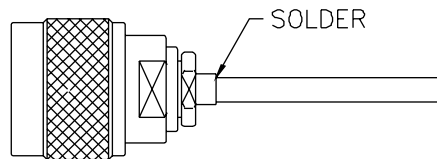

- STEP 1. All parts of the connector are shown.
- STEP 2. Strip the inner conductor, dielectric, and jacket as per "RECOMMENDED CABLE STRIPPING DIM'S" in catalog.
- STEP 3. Slide the INSULATOR onto inner conductor against the jacket. Then insert inner conductor into the CONTACT PIN and solder it as shown.
- STEP 4. Slide the SOLDER NUT onto cable.
- STEP 5. Insert cable and parts into the MAIN BODY, then screw the SOLDER NUT until it is tight and solder it as shown.

## CABLE ASSEMBLY INSTRUCTIONS

## CRIMP

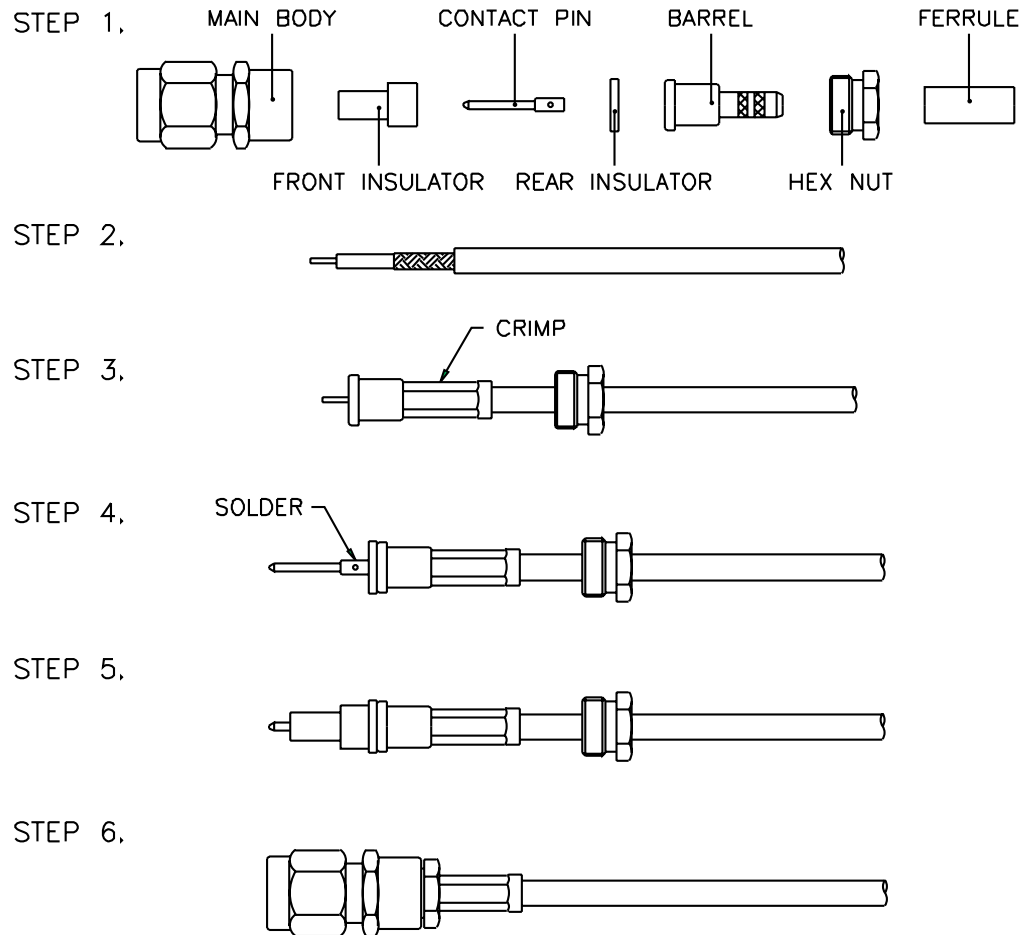

- STEP 1. All parts of the connector are shown.
- STEP 2. Strip the cable inner conductor, dielectric, braid, and jacket as per "RECOMMENDED CABLE STRIPPING DIM'S" in catalog.
- STEP 3. Slide the HEX NUT and FERRULE onto cable. Then insert the BARREL into braid and dielectric, and slide the FERRULE over braid and crimp it as shown.
- STEP 4. Slide the REAR INSULATOR against the BARREL. Then insert inner conductor into the CONTACT PIN and solder it as shown.
- STEP 5. Slide the FRONT INSULATOR against the REAR INSULATOR.
- STEP 6. Insert cable and parts into the MAIN BODY, then screw the HEX NUT until it is tight.

## CABLE ASSEMBLY INSTRUCTIONS

### CRIMP - CRIMP

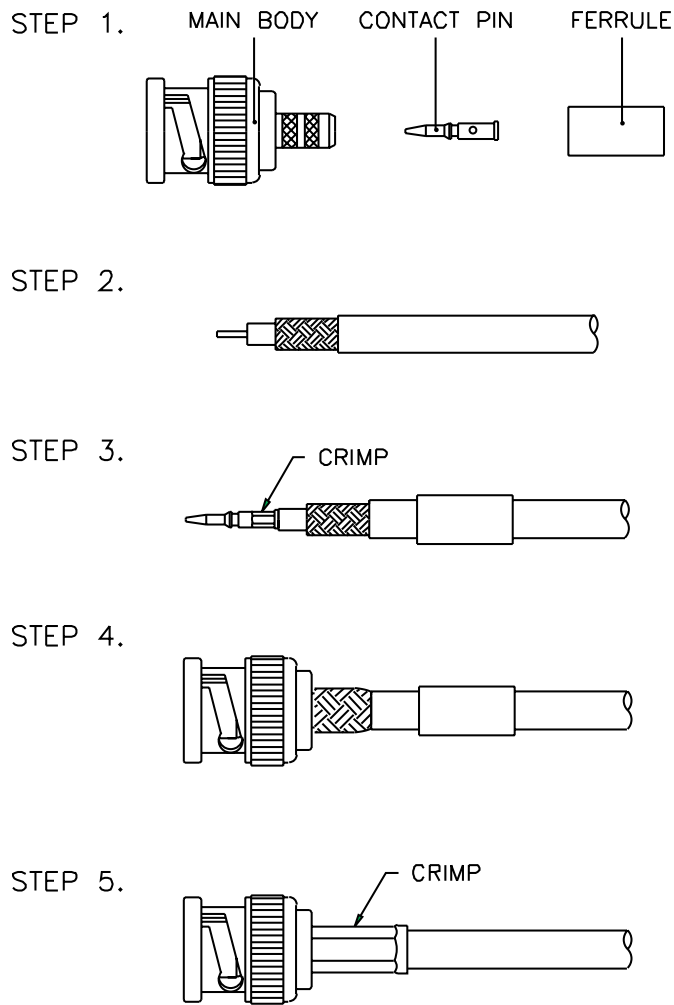

- STEP 1. All parts of the connector are shown. A crimp tool is necessary to complete the connection.
- STEP 2. Strip the cable inner conductor, dielectric, braid, and jacket as per "RECOMMENDED CABLE STRIPPING DIM'S" in catalog.
- STEP 3. Insert inner conductor into the CONTACT PIN, crimp it with the crimp tool as shown. Then slide the FERRULE onto cable.
- STEP 4. Insert the MAIN BODY into braid and dielectric.
- STEP 5. Slide the FERRULE over braid, crimp it with the crimp tool as shown.

## CABLE ASSEMBLY INSTRUCTIONS

### CRIMP - SOLDER

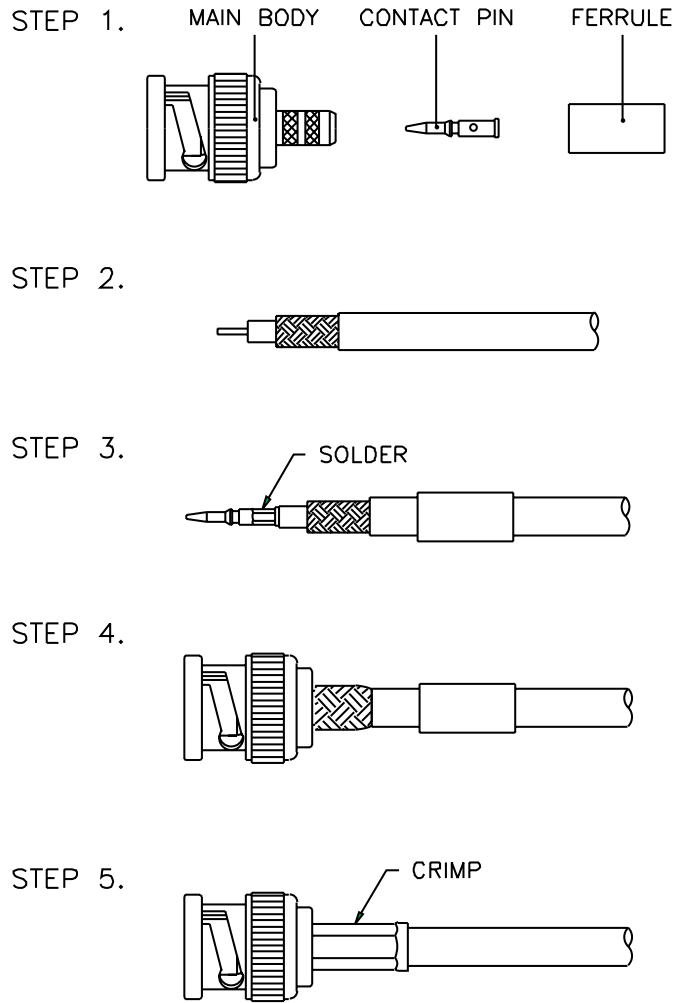

- STEP 1. All parts of the connector are shown. A crimp tool is necessary to complete the connection.
- STEP 2. Strip the cable inner conductor, dielectric, braid, and jacket as per "RECOMMENDED CABLE STRIPPING DIM'S" in catalog.
- STEP 3. Insert inner conductor into the CONTACT PIN and solder on the cable. Then slide the FERRULE onto cable.
- STEP 4. Insert the MAIN BODY into braid and dielectric.
- STEP 5. Slide the FERRULE over braid, crimp it with the crimp tool as shown.

## CABLE ASSEMBLY INSTRUCTIONS

### CRIMP - CRIMP

STEP 1,

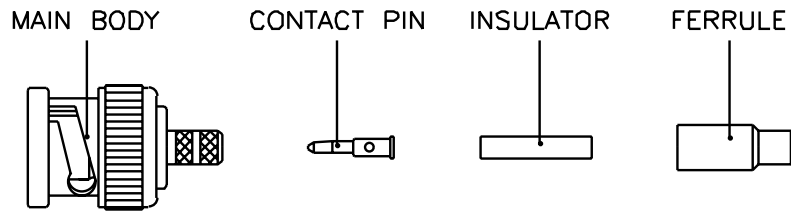

STEP 2,

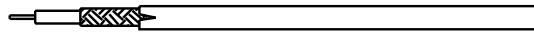

STEP 3,

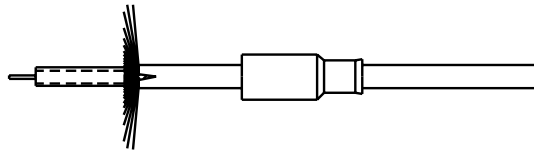

STEP 4,

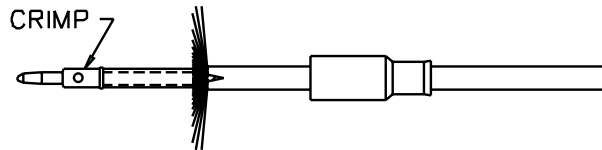

STEP 5,

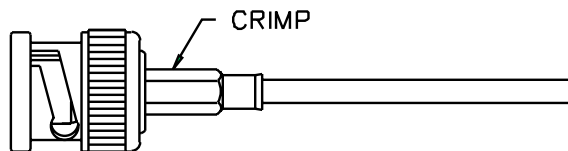

- STEP 1. All parts of the connector are shown. A crimp tool is necessary to complete the connection.
- STEP 2. Strip the inner conductor, dielectric, and jacket as per "RECOMMENDED CABLE STRIPPING DIM'S" in catalog.
- STEP 3. Slide the FERRULE onto cable, then fold back braid wire and slide the INSULATOR onto dielectric as shown.
- STEP 4. Insert inner conductor into the CONTACT PIN, crimp it with crimp tool as shown.
- STEP 5. Push cable and parts into the MAIN BODY until it stops. Then slide the FERRULE over braid wire and against the MAIN BODY, crimp it with the crimp tool as shown.

## CABLE ASSEMBLY INSTRUCTIONS

### CRIMP - CRIMP

STEP 1,

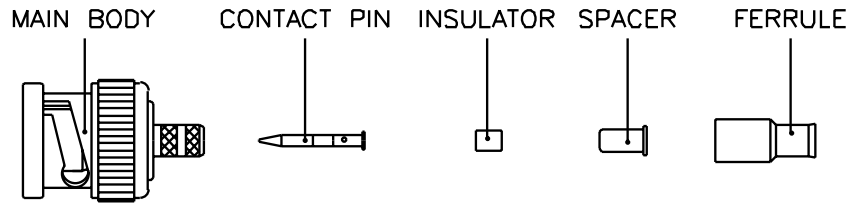

STEP 2,

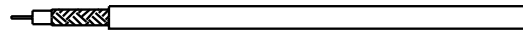

STEP 3,

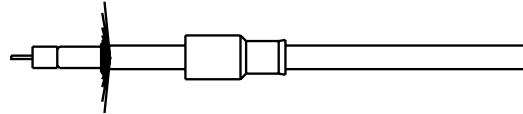

STEP 4,

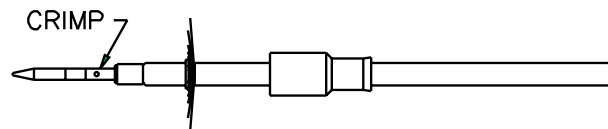

STEP 5,

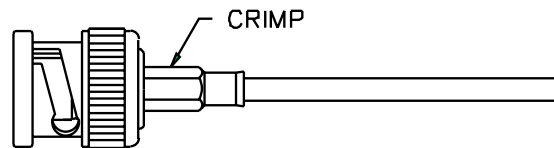

- STEP 1. All parts of the connector are shown. A crimp tool is necessary to complete the connection.
- STEP 2. Strip the cable inner conductor, dielectric, braid, and jacket as per "RECOMMENDED CABLE STRIPPING DIM'S" in catalog.
- STEP 3. Slide the FERRULE onto cable, then fold back braid wire and slide the SPACER and INSULATOR onto dielectric as shown.
- STEP 4. Insert inner conductor into the CONTACT PIN, crimp it with the crimp tool as shown.
- STEP 5. Push cable and parts into the MAIN BODY until it stops. Then slide the FERRULE over braid wire and against the MAIN BODY, crimp it with the crimp tool as shown.

## CABLE ASSEMBLY INSTRUCTIONS

### CLAMP - SOLDER

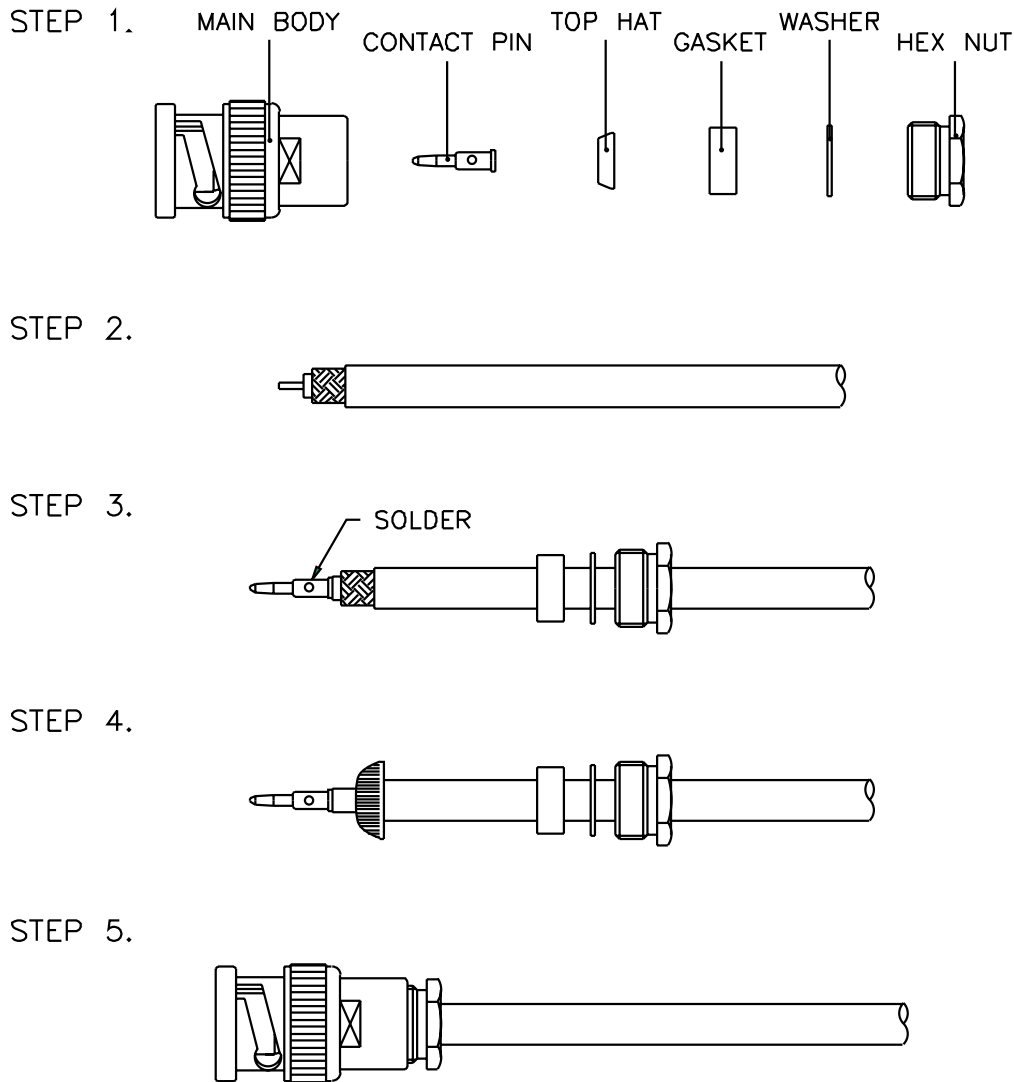

- STEP 1. All parts of the connector are shown.
- STEP 2. Strip the cable inner conductor, dielectric, and jacket as per "RECOMMENDED CABLE STRIPPING DIM'S" in catalog.
- STEP 3. Insert inner conductor into the CONTACT PIN and solder it as shown. Then slide the HEX NUT, WASHER, and GASKET onto cable one by one.
- STEP 4. Place the TOP HAT over braid and push back against cable jacket. Fold back braid wire as shown.
- STEP 5. Insert cable and parts into the MAIN BODY, then screw the HEX NUT until it is tightened.

## CABLE ASSEMBLY INSTRUCTIONS

### CLAMP - SOLDER

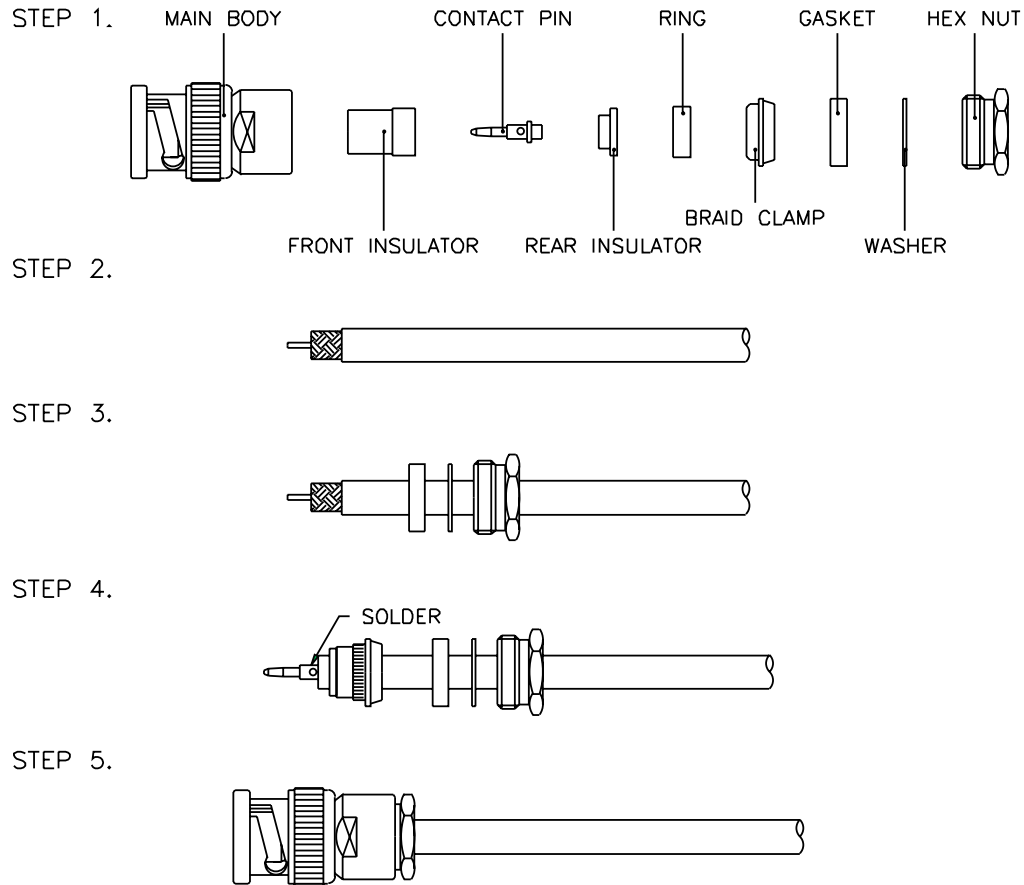

- STEP 1. All parts of the connector are shown.
- STEP 2. Strip the cable inner conductor, dielectric, and jacket as per "RECOMMENDED CABLE STRIPPING DIM'S" in catalog.
- STEP 3. Slide the HEX NUT, WASHER, and GASKET onto cable one by one.
- STEP 4. Place the BRAID CLAMP over braid and push back against cable jacket. Fold back braid wire as shown, and slide the RING and REAR INSULATOR against the BRAID CLAMP. Then insert inner conductor into the CONTACT PIN and solder it.
- STEP 5. Insert cable and parts into the MAIN BODY, then screw the HEX NUT until it is tightened.

## CABLE ASSEMBLY INSTRUCTIONS

### TWIST-ON

STEP 1.

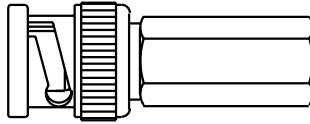

STEP 2.

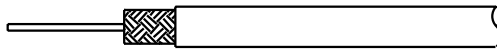

STEP 3.

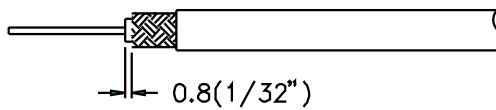

STEP 4.

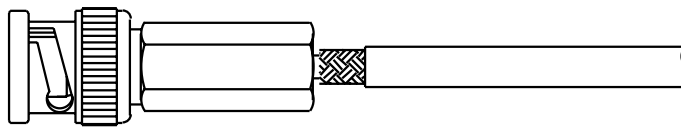

STEP 5.

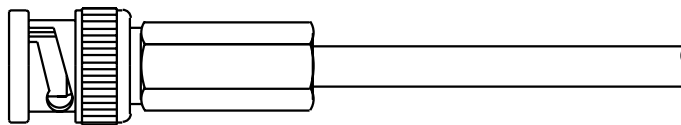

- STEP 1. The connector is shown.
- STEP 2. Strip the cable inner conductor, dielectric, braid, and jacket as per "RECOMMENDED CABLE STRIPPING DIM'S" in catalog.
- STEP 3. Twist braid in a clockwise direction so that at least 0,8mm of dielectric is bared, and braid is left flat.
- STEP 4. Insert inner conductor into the back end of connector gently, and feed it into the guide hole.
- STEP 5. Push and screw connector onto cable in a clockwise direction until it stops.

## CABLE ASSEMBLY INSTRUCTIONS

### WEDGE COMPRESSION

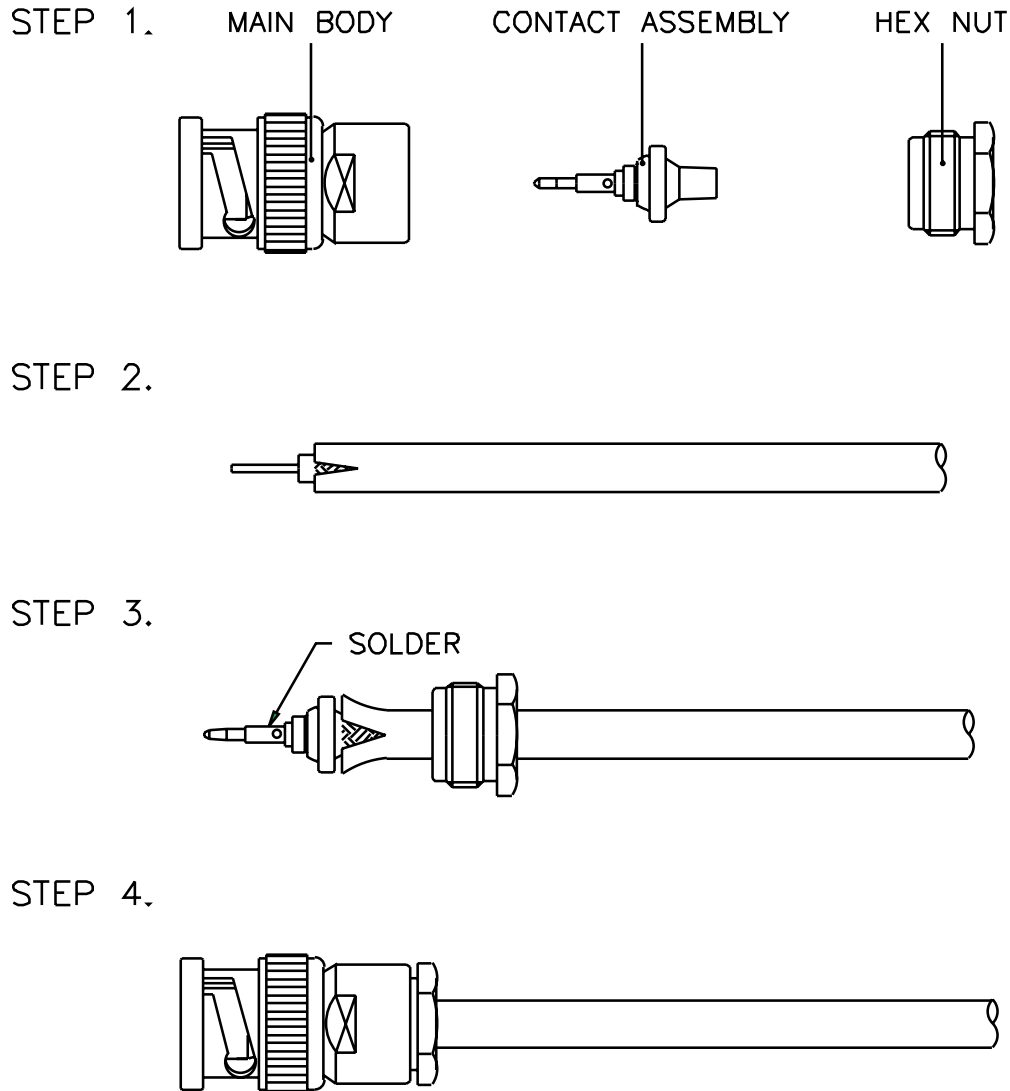

- STEP 1. All parts of the connector are shown.
- STEP 2. Strip the cable inner conductor, dielectric, and jacket as per "RECOMMENDED CABLE STRIPPING DIM'S" in catalog.
- STEP 3. Slide the HEX NUT onto cable, then insert the CONTACT ASSEMBLY under braid and jacket.
- STEP 4. Insert cable and parts into the MAIN BODY, then screw the HEX NUT until it is tight.

## CABLE ASSEMBLY INSTRUCTIONS

### CLAMP

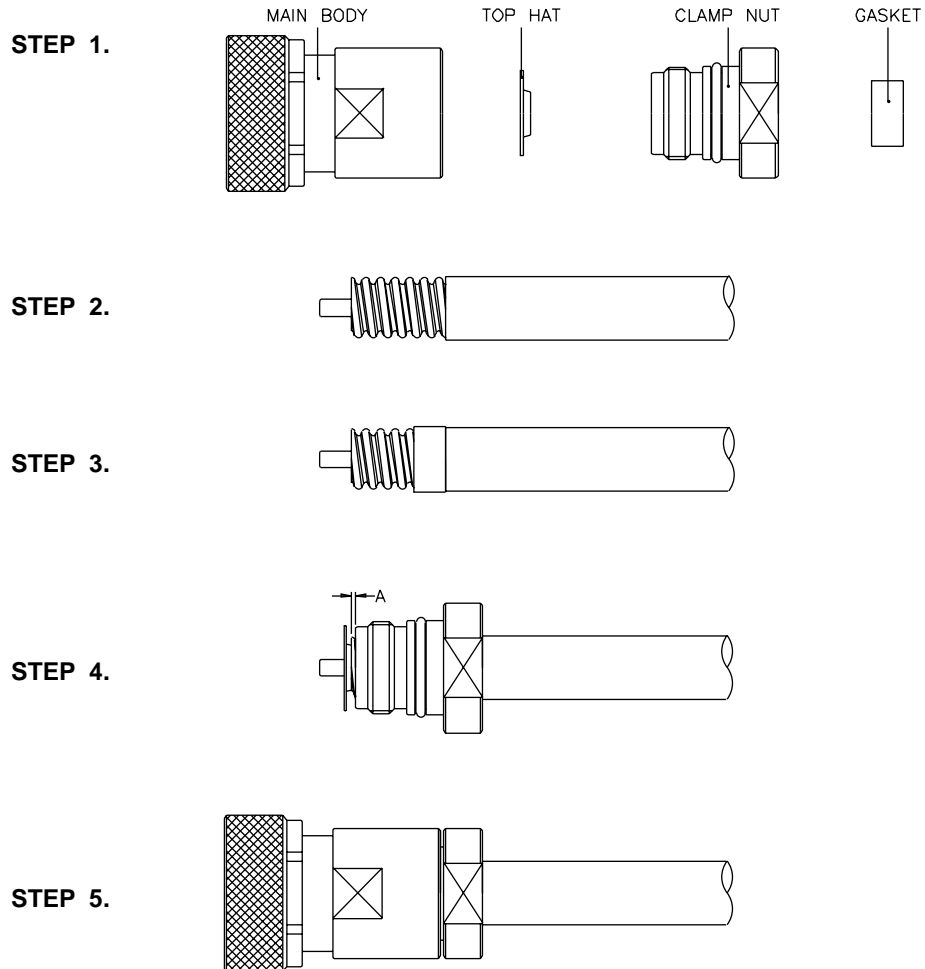

- STEP 1. All parts of the connector are shown.
- STEP 2. Strip the cable inner conductor, dielectric, outer conductor, and jacket as per "RECOMMENDED CABLE STRIPPING DIM'S" in catalog.
- STEP 3. Thread the GASKET onto the cable until it is against the cable jacket.
- STEP 4. Thread the CLAMP NUT onto the cable until the A dimension is 1-1.5 mm, then push the TOP HAT onto the outer conductor of cable inside as shown.
- STEP 5. Thread the MAIN BODY onto the CLAMP NUT and tighten the connection with wrenches, hold the CLAMP NUT and turn only the MAIN BODY.

## CABLE ASSEMBLY INSTRUCTIONS

### CLAMP

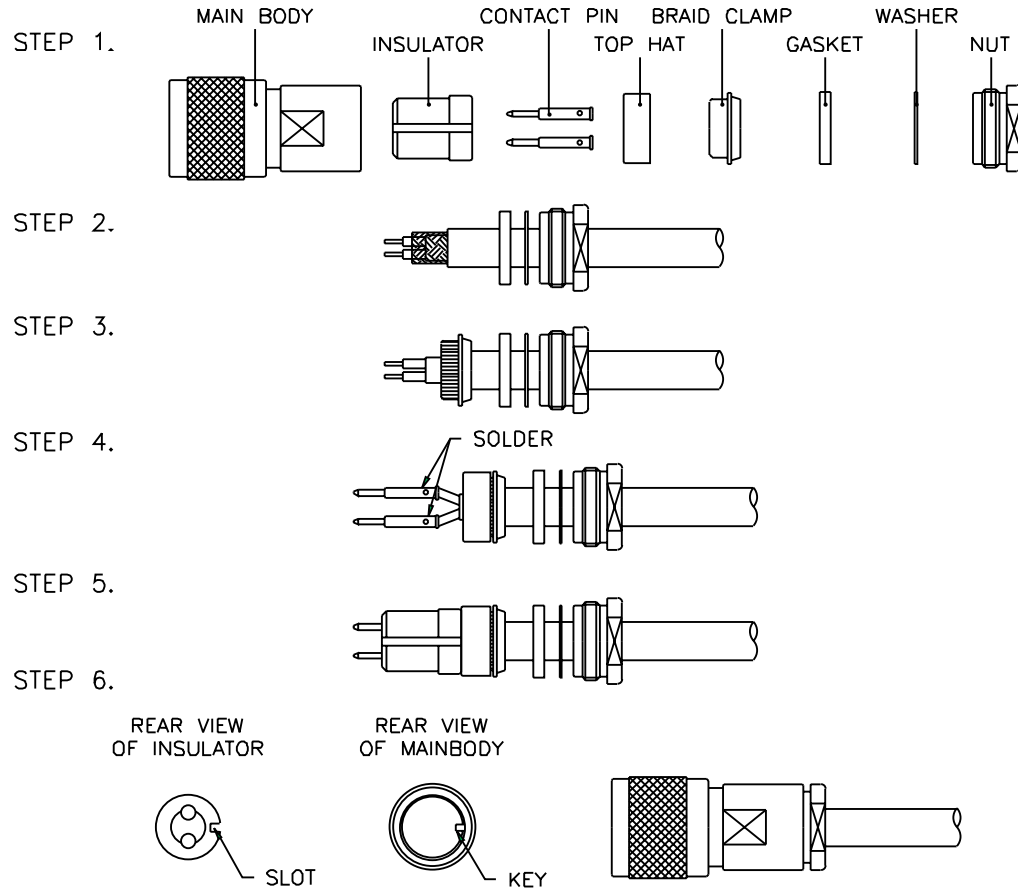

- STEP 1. All parts of the connector are shown.
- STEP 2. Strip the cable inner conductor, dielectric, and jacket as per "RECOMMENDED CABLE STRIPPING DIM'S" in catalog. Then slide the NUT, WASHER, and GASKET onto cable.
- STEP 3. Place the BRAID CLAMP over braid and push back against cable jacket. Fold back braid wire as shown.
- STEP 4. Slide the TOP HAT against the BRAID CLAMP. Then insert inner conductor into the CONTACT PINs and solder them.
- STEP 5. Insert the CONTACT PINs into the INSULATOR until the INSULATOR is against the TOP HAT.
- STEP 6. Insert cable and parts into the MAIN BODY, aligning slot of the INSULATOR with key in the MAIN BODY. Then screw the NUT until it is tight.

## CABLE ASSEMBLY INSTRUCTIONS

### SOLDER (US STANDARD)

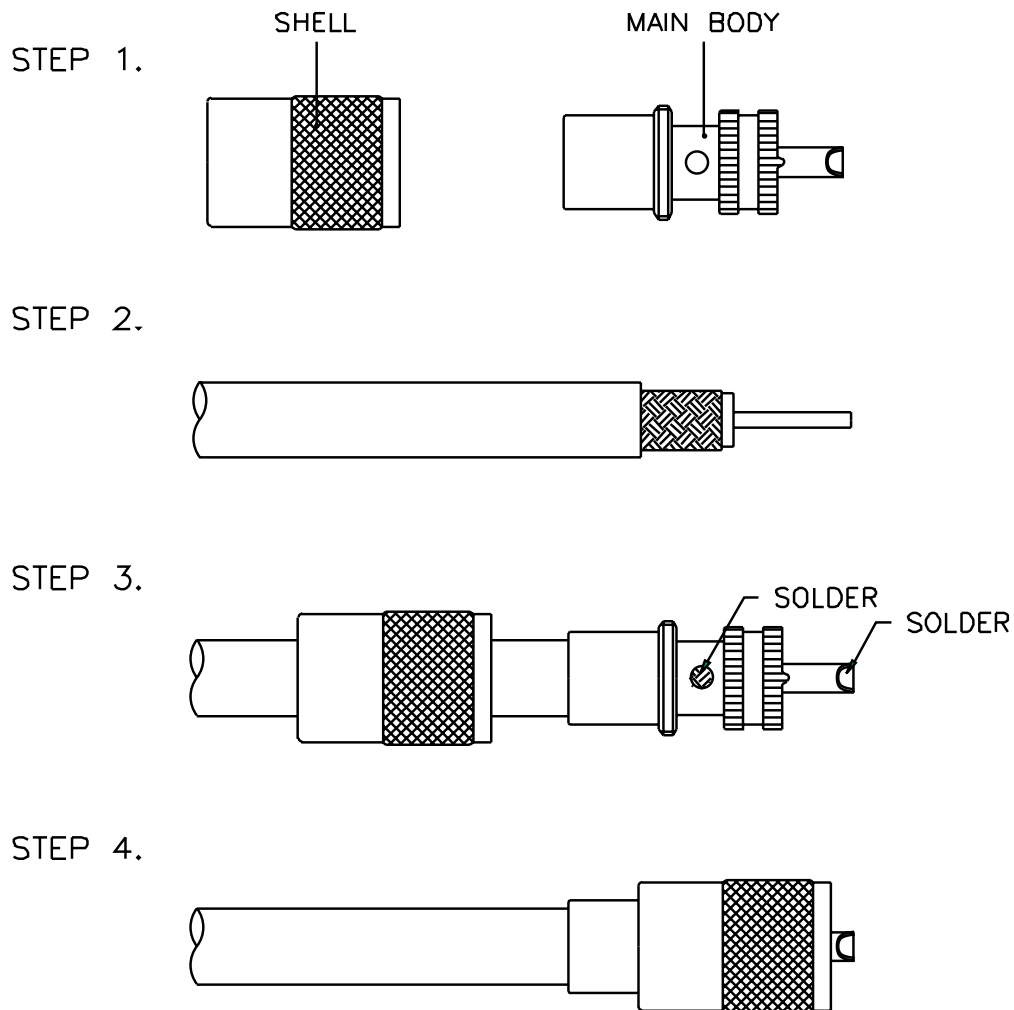

- STEP 1. All parts of the connector are shown.
- STEP 2. Strip the cable inner conductor, dielectric, braid, and jacket as per "RECOMMENDED CABLE STRIPPING DIM'S" in catalog.
- STEP 3. Slide the SHELL onto cable, then screw the MAIN BODY onto cable and solder it as shown.
- STEP 4. Slide the SHELL forward and screw in place on the MAIN BODY.

## CABLE ASSEMBLY INSTRUCTIONS

### SOLDER (WITH REDUCER)

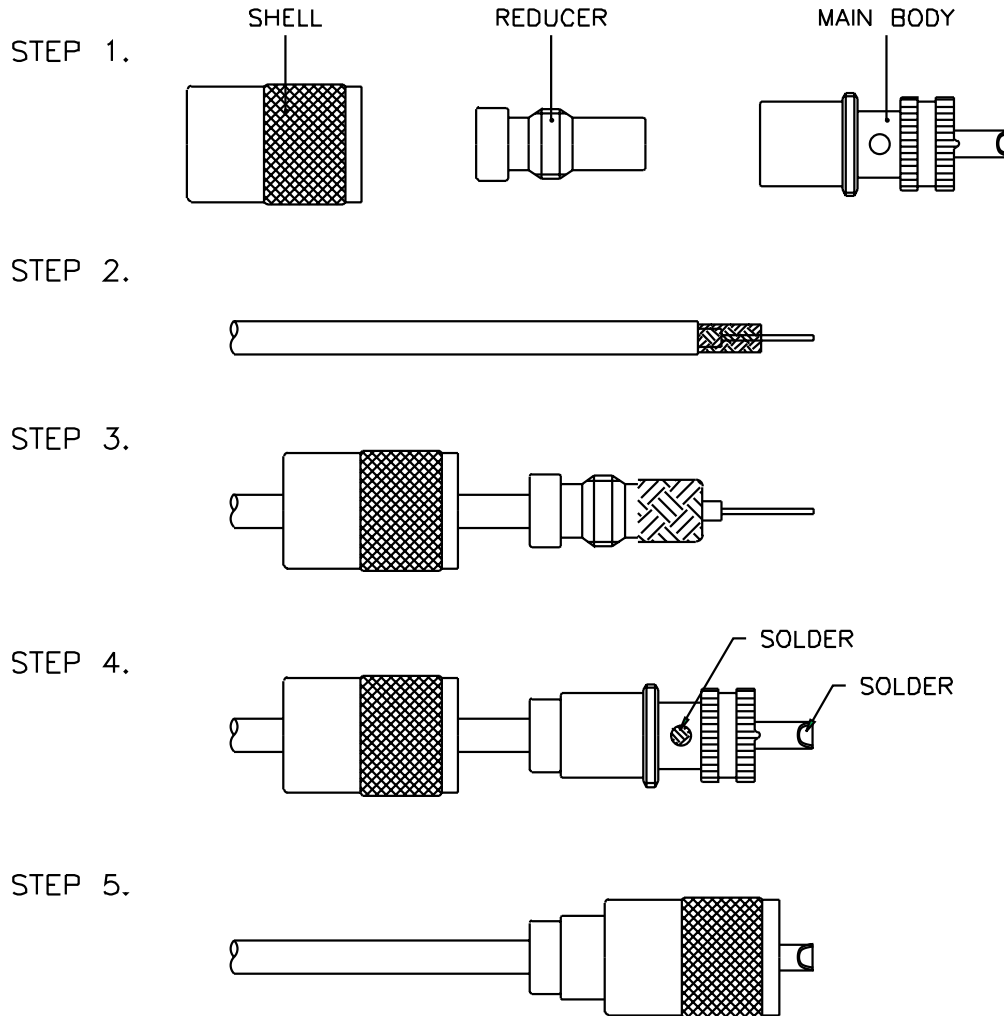

- STEP 1. All parts of the connector are shown.
- STEP 2. Strip the cable inner conductor, dielectric, braid, and jacket as per "RECOMMENDED CABLE STRIPPING DIM'S" in catalog.
- STEP 3. Slide the **SHELL** and **REDUCER** onto cable, then fold back braid wire over the **REDUCER** as shown.
- STEP 4. Screw the **MAIN BODY** onto the **REDUCER** and solder it as shown.
- STEP 5. Slide the **SHELL** forward and screw in place on the **MAIN BODY**.

## CABLE ASSEMBLY INSTRUCTIONS

### FCP

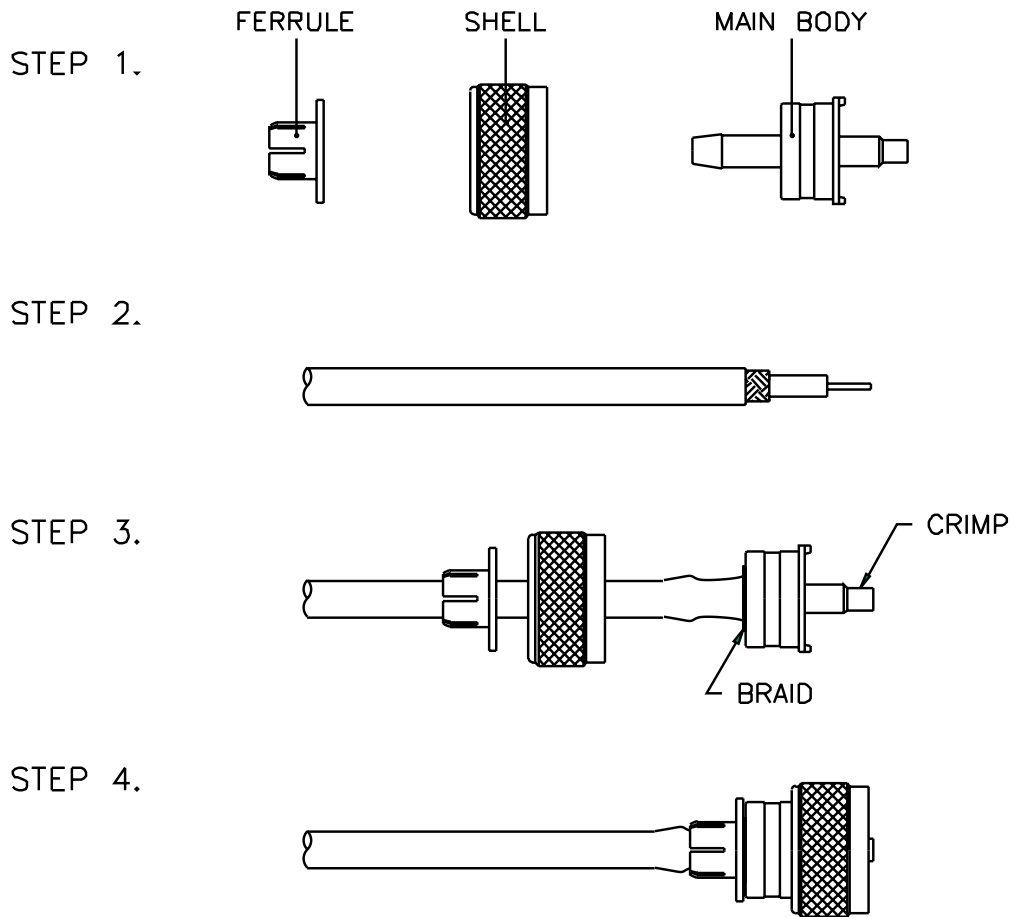

- STEP 1. All parts of the connector are shown.
- STEP 2. Strip the cable inner conductor, dielectric, braid, and jacket as per "RECOMMENDED CABLE STRIPPING DIM'S" in catalog.
- STEP 3. Slide the FERRULE and SHELL onto cable one by one, and insert the MAIN BODY into braid and dielectric until it is against cable jacket. Then crimp the CONTACT PIN as shown.
- STEP 4. Slide the SHELL onto the MAIN BODY, and push the FERRULE until it is against the MAIN BODY. If inner conductor sticks out beyond the CONTACT PIN, trim it.

## CABLE ASSEMBLY INSTRUCTIONS

### CRIMP - CRIMP

STEP 1.

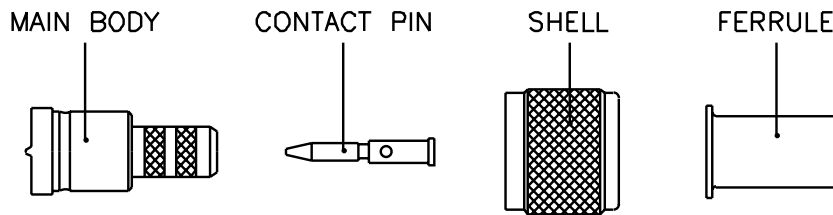

STEP 2.

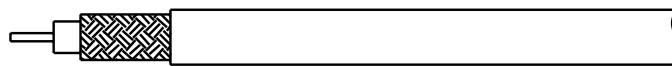

STEP 3.

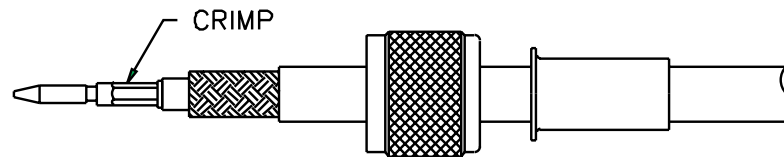

STEP 4.

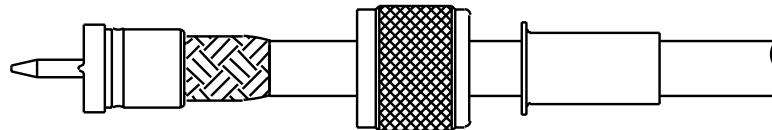

STEP 5.

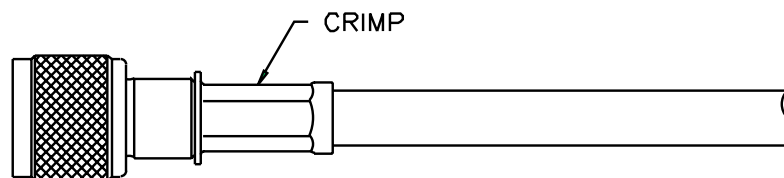

- STEP 1. All parts of the connector are shown. A crimp tool is necessary to complete the connection.
- STEP 2. Strip the cable inner conductor, dielectric, braid, and jacket as per "RECOMMENDED CABLE STRIPPING DIM'S" in catalog.
- STEP 3. Insert inner conductor into the CONTACT PIN, crimp it with the crimp tool as shown. Then slide the FERRULE and SHELL onto cable one by one.
- STEP 4. Insert the MAIN BODY under braid and dielectric.
- STEP 5. Slide the SHELL until it is against the MAIN BODY, then slide the FERRULE over braid, crimp it with the crimp tool as shown.

## CABLE ASSEMBLY INSTRUCTIONS

### CRIMP

#### STEP 1.

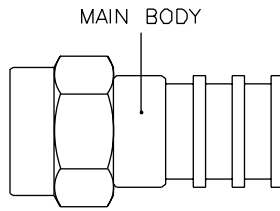

#### STEP 2.

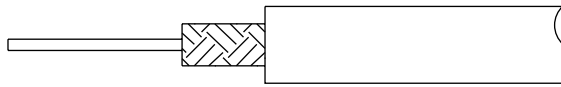

#### STEP 3.

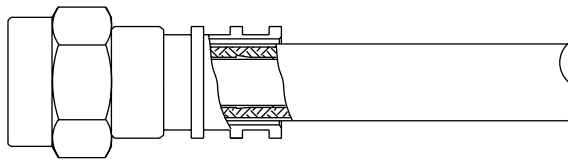

#### STEP 4.

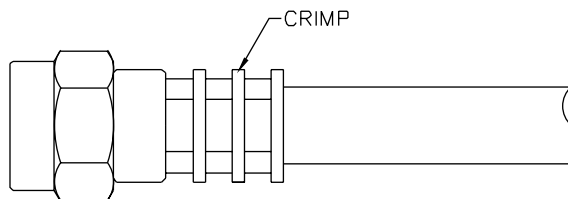

- STEP 1. All parts of the connector are shown. A crimp tool is necessary to complete the connection.
- STEP 2. Strip the inner conductor, dielectric, braid, and jacket as per "RECOMMENDED CABLE STRIPPING DIM'S" in catalog.
- STEP 3. Insert cable into the back end of MAIN BODY gently, and feed it into the guide hole.
- STEP 4. Crimp it with the crimp tool as shown.

## CABLE ASSEMBLY INSTRUCTIONS

### CRIMP

#### STEP 1.

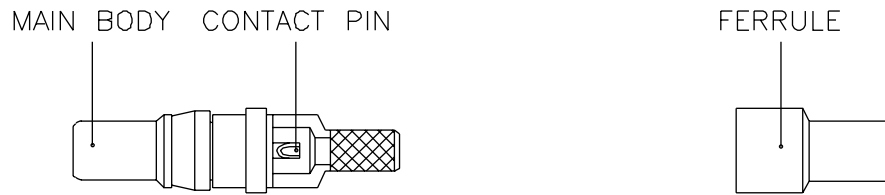

#### STEP 2.



#### STEP 3.

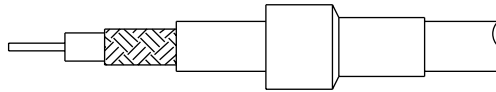

#### STEP 4.

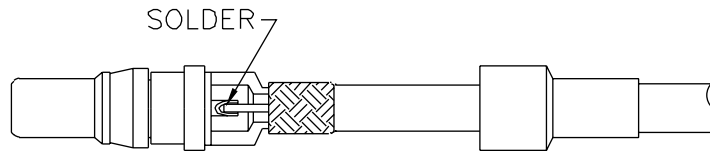

#### STEP 5.

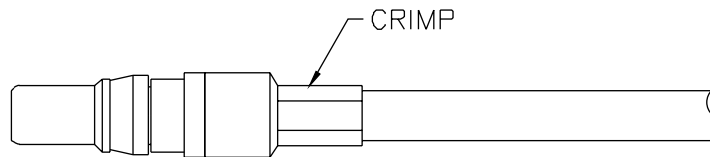

STEP 1. All parts of the connector are shown. A crimp tool is necessary to complete the connection.

STEP 2. Strip the inner conductor, dielectric, braid, and jacket as per "RECOMMENDED CABLE STRIPPING DIM'S" in catalog.

STEP 3. Slide the FERRULE onto cable.

STEP 4. Solder inner conductor to contact pin of the MAIN BODY as shown.

STEP 5. Slide the FERRULE over braid; crimp it with the crimp tool as shown.