

ELECTRICAL

Impedance	50 Ohms nominal
Frequency range	DC - 200 MHz

MATERIAL

Body, coupling sleeve, male contact	Brass
Female contact	Phosphor bronze
Crimp ferrule	Brass
Plating	Contacts: gold Other metal parts: Nickel
Insulator	Teflon or Delrin

MECHANICAL

Mating	M8XP .75 thd.
Cable affixment	Crimp

PLUG

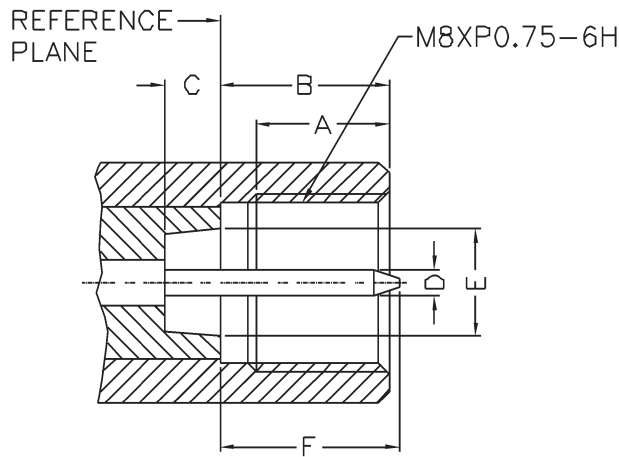

JACK

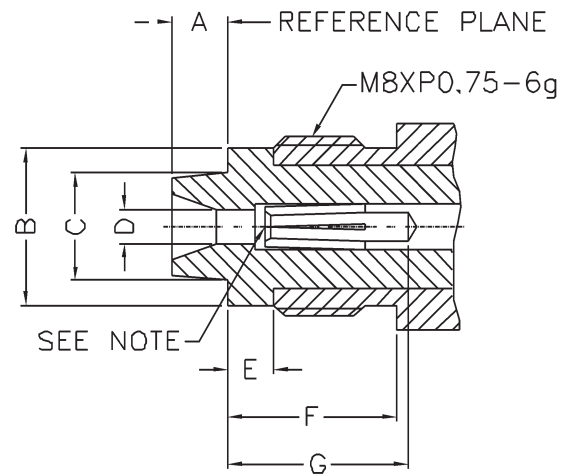

LTR	INCHES		MILLIMETERS	
	MIN	MAX	MIN	MAX
A	.220	—	5.60	—
B	.298	.300	7.58	7.62
C	.098	—	2.50	—
D	.046	.048	1.17	1.23
E	.189	—	4.80	—
F	—	.315	—	8.00

LTR	INCHES		MILLIMETERS	
	MIN	MAX	MIN	MAX
A	—	.098	—	2.50
B	—	.276	—	7.00
C	—	.189	—	4.80
D	.051	—	1.30	—
E	.087	—	2.20	—
F	.315	—	8.00	—
G	.315	—	8.00	—

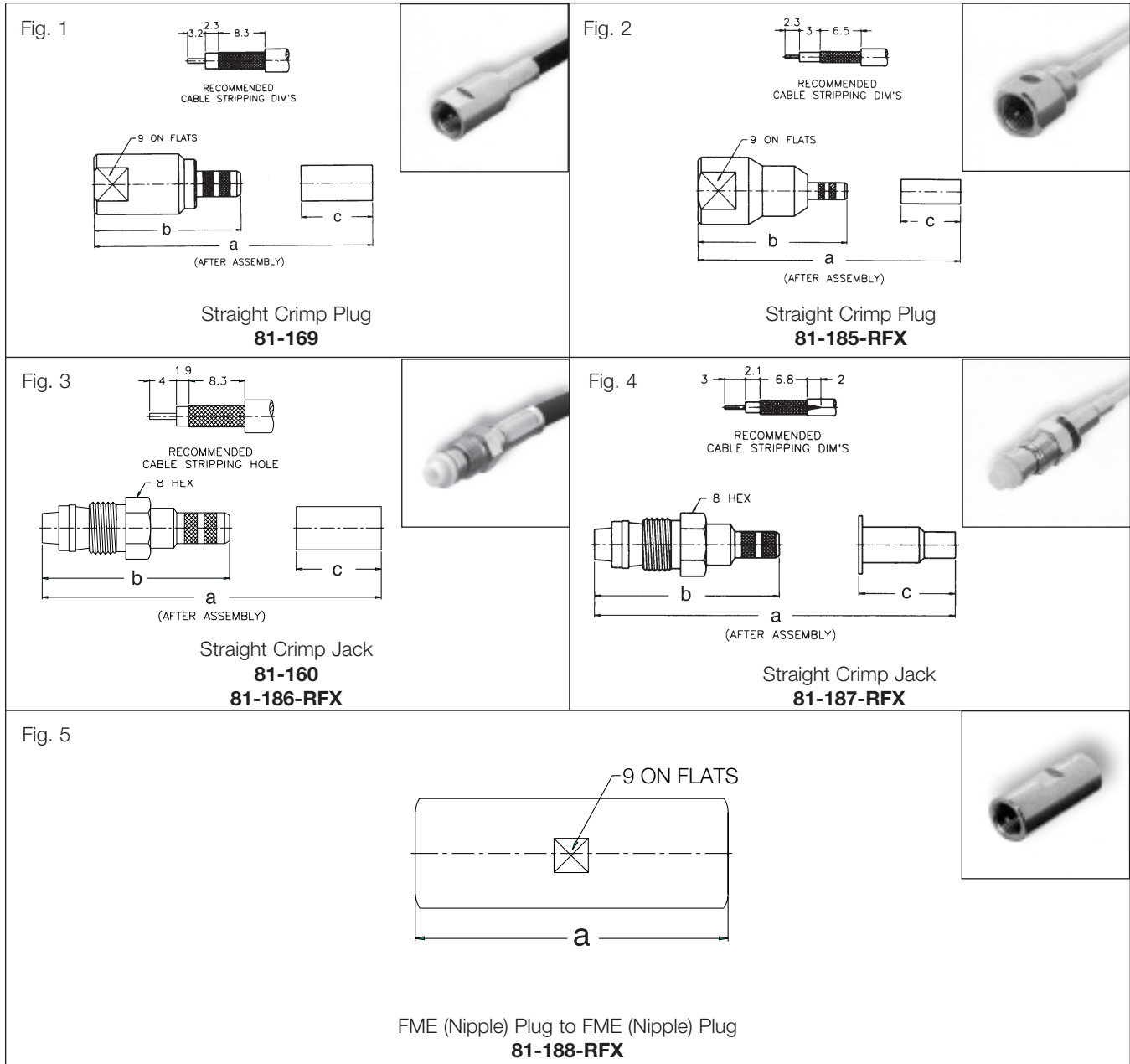

FME

STRAIGHT CRIMP PLUGS & JACKS, ADAPTER

Cable RG-/U	Description	Cable Termination	Dimensions, in. (mm)			Construction Notes			Other	Amphenol Number	Fig
			a	b	c	CAI	Plt.	Ins.			
58, 141, 142	Plug	Crimp	1.21 (30.8)	1.02 (26.0)	.500 (12.7)	C22	P15	D1	—	81-169	1
174, 188, 316	Plug	Crimp	1.06 (26.9)	.933 (23.7)	.374 (9.5)	C22	P15	D1	—	81-185-RFX	2
58, 141, 142	Jack	Crimp	1.29 (32.8)	1.10 (28.0)	.500 (12.7)	C22	P15	D1	—	81-160	3
58, 141, 142	Jack	Crimp	1.29 (32.8)	1.10 (28.0)	.500 (12.7)	C22	P15	D23	non-captive	81-186-RFX	3
174, 188, 316	Jack	Crimp	1.34 (34.1)	1.04 (26.5)	.500 (12.7)	C22	P15	D23	—	81-187-RFX	4
—	Plug-Plug Adapter	—	1.02 (26.0)	—	—	C22	P1	D23	—	81-188-RFX	5